

## FR MONTAGE DE LA SUSPENSION *WRIGHT*

1. Passez les fils dans le tube A (110cm de long). Pour diminuer la hauteur de votre suspension, le tube A peut être raccourci au moyen d'une scie à métaux.
2. Vissez le tube A dans le trou fileté de la suspension. Répétez cette opération pour le deuxième tube A.
3. Fixez les manchons B sur le boîtier C et serrez le tout à l'aide des rondelles éventails, des écrous hexagonaux et d'une clé de 13mm.
4. Glissez les manchons B sur les tubes A en faisant suivre les fils électriques. Ajustez la hauteur de la suspension en serrant les petites vis des manchons B à l'aide de la clé Allen qui vous est fournie.
5. Fixez la patère D au plafond et raccordez le fil de terre à la connexion prévue.
6. Raccordez votre arrivée de courant aux connexions électriques du lustre et fixez le boîtier C sur la patère D à l'aide des deux vis latérales.

## NL MONTAGE VAN DE SUSPENSIE *WRIGHT*

1. Glijd de draden door buis A (110cm lang). Om de hoogte van de suspensie te verminderen kan de buis A d.m.v. een metaalzaag korter gemaakt worden.
2. Schroef buis A in de voorziene schroefdraad van de suspensie. Herhaal deze operatie voor de tweede buis.
3. Bevestig de buizen B aan doos C met behulp van de growers, de hexagonale moeren en met een sleutel van 13mm.
4. Glijd de buizen B op de buizen A en laat de elektrische draden volgen. Stel de hoogte van de suspensie in door de kleine schroef van de buis B vast te draaien door middel van de inbusleutel die meegeleverd is.
5. Bevestig het plafondplaatje D aan het plafond en bevestig de aarding aan de voorziene aansluiting.
6. Verbind de stroomtoegang aan de elektrische aansluitingen van de suspensie en bevestig doos C op het bevestigingsplaatje D met behulp van de 2 zijschroeven.

## EN MOUNTING OF THE SUSPENSION *WRIGHT*

1. Slide the wires through tube A (110cm long). To adjust the height of the suspension, tube A can be made shorter by a metal saw.
2. Screw tube A in the provided screw thread from the suspension. Repeat this operation for the other tubes.
3. Attach the tubes B to the box C and tighten everything.
4. Slide tubes B on the tubes A and let follow the electric wires. Set the height of the suspension in through tightening the small screw from tube B with the included Allen wrench.
5. Attach the ceiling plate D to the ceiling and attach the grounding wire to the provided connection.
6. Connect the power access to the electrical connections of the suspension and attach box C on the mounting plate D using the 2 side screws.

## DE PLATZIERUNG DER PENDELLEUCHTE *WRIGHT*

1. Schieben Sie die Drähte durch Rohr A (110cm lange). Die Höhenverstellung der Pendelleuchte kann durch eine Metallsäge das Rohr B kürzer gestaltet werden.
2. Schrauben Sie Rohr A in das Schraubengewinde in die Pendelleuchte. Wiederholen Sie diesen Vorgang für den andere Röhre.
3. Befestigen Sie die Rohre B auf Box C und schalten Sie alles.
4. Schieben Sie Rohr B auf das Rohr A und lassen Sie die elektrischen Leitungen folgen. Stellen Sie die Höhe der Leuchter in durch die kleine Schraube aus Rohr B fest zu ziehen mit den Inbuschlüssel, den Sie enthalten.
5. Bringen Sie die Befestigungsplatte D an der Decke und befestigen Sie die Erdung an den angegebenebenen Anschluss.
6. Schließen Sie den Stromzugang an die elektrischen Anschlüsse von der Pendelleuchte und befestigen Sie Box C auf der Montageplatte D mit den 2 seitlichen Schrauben.

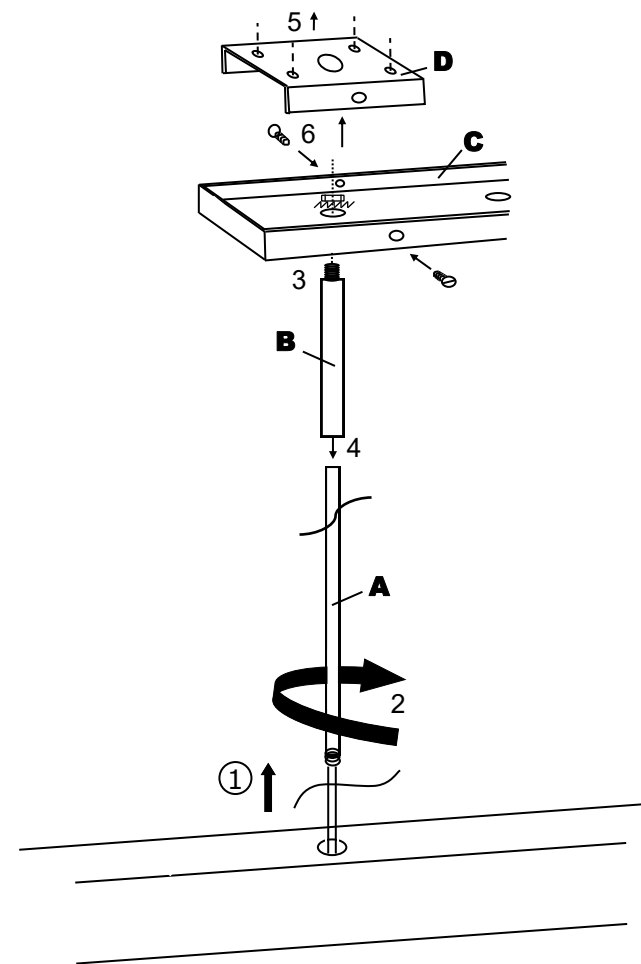

# WRIGHT





Manufacturer : DAVIDTS LIGHTING – Brussels – Belgium – [www.davidts.com](http://www.davidts.com)

## Installation and security instructions (please read and save)

This luminaire is manufactured according to European directives and standards relating to quality and safety of lighting fixtures. A declaration of conformity is available by downloading on our site.

### Description of the lighting

Lighting for fixing to the wall or ceiling with handmade shade(s) with a soft and pleasant light distribution. More pictures, drawings and complete descriptions are available on our website.

### Environmental protection

Our packaging is made from 100% recyclable or re-usable material. For care of the environment please sort or recycle. Fluorescent bulbs and waste electrical equipment should not be disposed of with household waste please take to a recycling facility. This fixture is essentially composed of solid brass. This metal and other elements are fully recyclable. At end of life, if you take the fixture to a recycling facility, each metal will be recovered for new metal production.

### Installation of the lighting

This lighting is only intended for indoor use, it must be installed away from moisture, splashing and sources of heat. Suitable for direct mounting on normally flammable surfaces. Before starting the installation, ensure the electrical supply is OFF at the circuit breaker in the consumer unit. Only switching OFF at the wall switch is not adequate.

Carefully remove all packaging. All of our fixtures are fixed to the wall or to the ceiling by means of a mounting plate (placement is done by means of screws and dowels, not supplied). Some of our luminaires have more detailed installation instructions (attached to this document). Please read carefully before starting the installation.

If your light lighting has a fitting with shade ring, unscrew it in order to secure the shade to the fitting. If the shade is made with a seam, make sure that it is positioned towards the back of the light. Screw down the ring carefully. Place the bulb (not supplied) without forcing into the fitting. If necessary straighten the shade, only by carefully flexing the metal rods of the shade.

If you have any doubt about the installation of this lighting, please contact a qualified electrician.

### Inserting or replacing a bulb

Always ensure the electrical supply is OFF before this operation. If necessary, let the old bulb to cool for 10 minutes before removing. Place the bulb without forcing into the fitting. Do not directly touch it with the fingers, but with a cloth (fingerprints reduce the lifetime of a bulb). Be always attentive to the choice of a bulb, never exceed the maximum power (W) authorized, indicated on the labels of the light fitting. If an integral LED bulb attached to the fixture is defective, please contact your distributor.

### Maintenance of your shades

When your shade is dusted use only a brush suitable for delicate fabrics. Never rub the shade with a damp cloth or with water. Stains or marks on shades can't be removed, attempting removal will risk increasing the surface of the stain. In the case of a disaster, only a new shade can recover the original beautiful aspect and clarity of your lighting. To do this please contact your distributor.

### Maintenance of your lighting

Because smoke and dust particles in the air are attracted by a heat source, a deposit will appear on the fixture in the course of time. For maintenance, allow the bulb to cool for at least 10 minutes. Clean the fixture with a paper towel soaked with glass cleaner. Never use solvents, abrasive or corrosive products. Never immerse the fixture in water. If the wires are damaged, they must be replaced by a qualified electrician. This fixture must never be modified as this can make it dangerous to use.