

FR MONTAGE de la suspension LUNGA \emptyset (sur faux-plafond)

- 1 Avec 6 vis et chevilles standards placez les deux patères de fixation au plafond (entraxe de 48cm).
- 2 & 3 Replacez les 2 plaques décoratives sur les 2 patères au moyen des petites vis en laiton.
- 4 Insérez les deux câbles en acier dans les serres-câbles au centre de chaque fixation et réglez la hauteur de la suspension.
- 5 Découpez un trou $\emptyset 50\text{mm}$ dans le faux-plafond au centre de l'entraxe des deux patères de fixation.
- 6 Placez dans le faux-plafond le convertisseur et raccordez-le au 240V (*primaire*). Enfilez le câble d'alimentation dans la plaque avec les clips, raccordez-le au 24V du convertisseur (*secondaire*) et refermez le trou du plafond (clips + plaque).

NL MONTAGE van de hanglamp LUNGA \emptyset (met vals plafond)

- 1 Bevestig de 2 beugels aan het plafond met 6 standaard schroeven en pluggen met een tussen afstand van 48cm.
- 2 & 3 Plaats de 2 decoratieve platen terug op de 2 beugels met behulp van de kleine messing schroeven.
- 4 Steek de twee staalkabels in de kabelklemmen in het midden van elke beugel en stel de hoogte van de hanglamp in.
- 5 Maak een gaatje van $\emptyset 50\text{mm}$ in het vals plafond in het midden van de afstand tussen de twee beugels.
- 6 Plaats de driver in het vals plafond en sluit hem aan het 240V (*primary*). Steek de voedingskabel in het deksel met clips, sluit hem aan de 24V van de driver (*secondary*) en sluit het gat in het plafond (clips + plaat).

EN MOUNTING of the suspension LUNGA \emptyset (on false ceiling)

- 1 Attach the 2 fixing plates to the ceiling with 6 standard screws and plugs (center distance of 48 cm).
- 2 & 3 Place the 2 decorative plates back on the 2 fixing plates using the small brass screws.
- 4 Insert the two steel cables into the cable clips in the middle of each fixing plate and adjust the height of the suspension.
- 5 Make a cut-out of $\emptyset 50\text{mm}$ in the false ceiling in the middle of the distance between the two fixing plates.
- 6 Place the driver in the false ceiling and connect it to 240V (*primary*). Put the power cable in the plate with clips, connect it to the 24V of the driver (*secondary*) and close the ceiling hole (clips + plate).

DE MONTAGE der Pendelleuchte LUNGA \emptyset (mit Zwischendecke)

- 1 Befestigen Sie die 2 Montageplatten mit 6 Standardschrauben und Dübeln in einem Abstand von 48 cm an der Decke.
- 2 & 3 Bringen Sie die 2 Zierplatten mit den kleinen Messingschrauben wieder an den 2 Montageplatten an.
- 4 Führen Sie die beiden Stahlseile in die Kabelklemmen in der Mitte jeder Montageplatte ein und stellen Sie die Höhe der Pendelleuchte ein.
5. In der Zwischendecke in der Mitte des Abstands zwischen den beiden Montageplatten einen Ausschnitt von $\emptyset 50\text{ mm}$ anbringen.
6. Platzieren Sie den Konverter in der Zwischendecke und schließen Sie ihn an 240 V (*Primary*) an. Legen Sie das Stromkabel in die Abdeckung mit Klammern, schließen Sie es an die 24V der Konverter (*Secondary*) an und schließen Sie die Aussparung (Klammern + Platte).

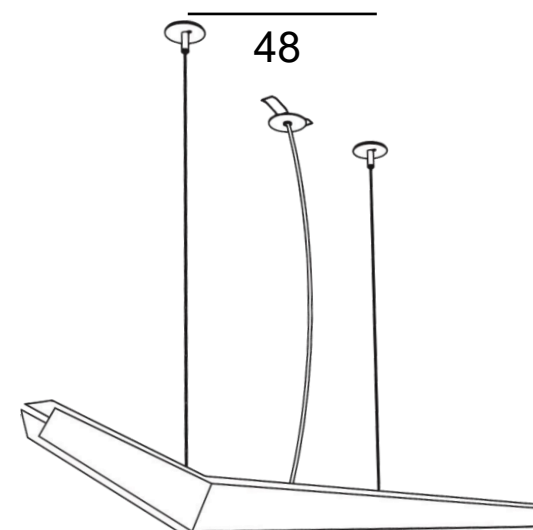
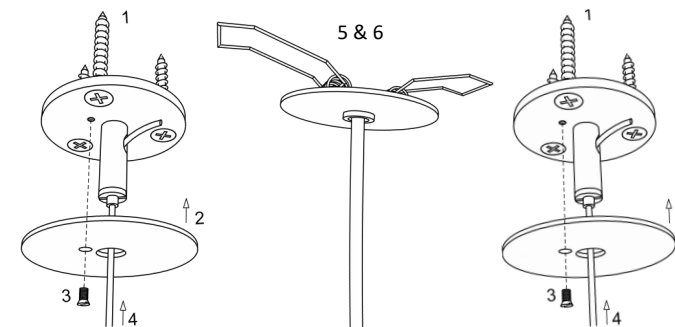

LUNGA \emptyset





Manufacturer : DAVIDTS LIGHTING – Brussels – Belgium – www.davidts.com

Installation and security instructions (please read and save)

This luminaire is manufactured according to European directives and standards relating to quality and safety of lighting fixtures. A declaration of conformity is available by downloading on our site.

Description of the lighting

Lighting for fixing to the wall or ceiling. More pictures, drawings and complete descriptions are available on our website.

Environmental protection

Our packaging is made from 100% recyclable or re-usable material. For care of the environment please sort or recycle. Fluorescent bulbs and waste electrical equipment should not be disposed of with household waste please take to a recycling facility. This fixture is essentially composed of solid brass. This metal and other elements are fully recyclable. At end of life, if you take the fixture to a recycling facility, each metal will be recovered for new metal production.

Installation of the lighting

This lighting is only intended for indoor use, it must be installed away from moisture, splashing and sources of heat. Suitable for direct mounting on normally flammable surfaces. Before starting the installation, ensure the electrical supply is OFF at the circuit breaker in the consumer unit. Only switching OFF at the wall switch is not adequate. Carefully remove all packaging. All of our fixtures are fixed to the wall or to the ceiling by means of a mounting plate (placement is done by means of screws and dowels, not supplied). Some of our luminaires have more detailed installation instructions (attached to this document). Please read carefully before starting the installation. If you have any doubt about the installation of this lighting, please contact a qualified electrician.

Inserting or replacing a bulb

Always ensure the electrical supply is OFF before this operation. If necessary, let the old bulb to cool for 10 minutes before removing. Place the bulb without forcing into the fitting. Do not directly touch it with the fingers, but with a cloth (fingerprints reduce the lifetime of a bulb). Be always attentive to the choice of a bulb, never exceed the maximum power (W) authorized, indicated on the labels of the light fitting. If an integral LED bulb attached to the fixture is defective, please contact your distributor.

Maintenance of your lighting

Because smoke and dust particles in the air are attracted by a heat source, a deposit will appear on the fixture in the course of time. For maintenance, allow the bulb to cool for at least 10 minutes. Clean the fixture with a paper towel soaked with glass cleaner. Never use solvents, abrasive or corrosive products. Never immerse the fixture in water. If the wires are damaged, they must be replaced by a qualified electrician. This fixture must never be modified as this can make it dangerous to use.