

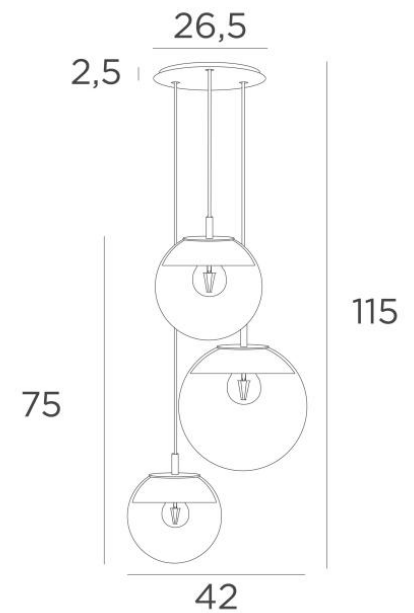

LUNA 3 o26



LUNA 3o26 structured black (code 02) with transparent glasses (code 80)



LUNA 3 o26, all in crescents that dress every glass perfectly

Composed of a beautiful composition with glasses of different sizes, this suspension will be the attraction of your decoration

The dimmer ensures the right light intensity at any time of the day or night

LUNA 3 o26 is simply in line with current lighting fixtures

OVERALL SIZES

H115cm Ø42cm **Ceiling base 3 o26** : Ø26,5 x 2,5cm

TECHNICAL DATA

The LUNA 3 o26 suspension includes :

A ceiling base and textile cables. Other sizes are possible, see [ORDER FORM](#)

Glass closings devices, fittings (1x E14 and 2x E27) and dimmable LED bulbs

The "SPHERE" glasses are additional. Four glass colors to choose from :

transparent (80), grey (89), anthracite (82) or amber (85)

One SPHERE Small (code 4445 - Ø22cm - 1,2 kg)

One SPHERE Medium (code 4446 - Ø25cm - 1,6 kg)

One SPHERE Large (code 4447 - Ø30cm - 2,7 kg)

AVAILABLE METAL FINISHES AND CODES

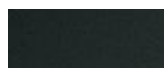

02 - Structured black - 4482 002



25 - Brushed brass - 4482 025



28 - Light bronze - 4482 028



29 - Brushed bronze - 4482 029



LIGHTING COLLECTION