

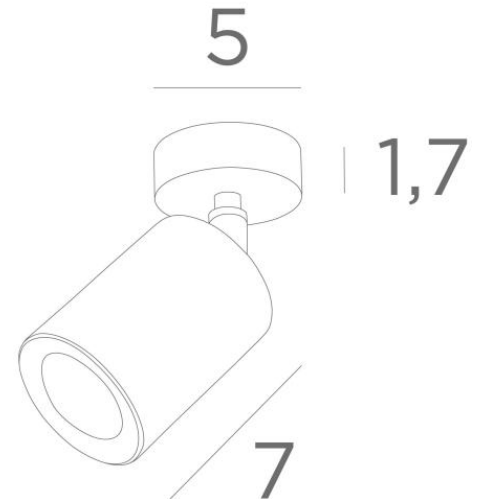

## SIRIUS MOBILE



SIRIUS MOBILE in structured black. Metal finish code: 02

**SIRIUS** is a small spotlight, unique in his range, with a clean design and an original touch. He has become an essential part of the **Lighting Collection**

Discreet and very useful to add a little more light to your interior. He is designed to be easily installed on a ceiling, and mobile in all directions. To equip it, there are GU10 bulbs of very high power on the market

### OVERALL SIZES

Ø5cm    H7,5→12,3cm

**BASE** : Ø5 x 1,7cm

### TECHNICAL DATA

One spotlight mounted on a 360° adjustable joint





Spotlight dimensions : Ø5,3cm L7cm

One GU10 fitting. Dimmable spotlight

No driver, this spotlight works directly on 230V

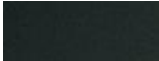
A fixing plate for the ceiling base ([plan in PDF](#))

### AVAILABLE METAL FINISHES AND CODES

	01 - Structured white - 5182 001
	02 - Structured black - 5182 002
	25 - Brushed brass - 5182 025
	28 - Light bronze - 5182 028
	29 - Brushed bronze - 5182 029
	32 - Brushed chrome - 5182 032

